

# Safety and Assembly Instructions

## IMPORTANT

READ AND FOLLOW ALL SAFETY INFORMATION AND INSTRUCTIONS, KEEP FOR FUTURE REFERENCE



**WARNING!**  
CHOKING HAZARD-SMALL PARTS, NOT FOR CHILDREN UNDER 3 YEARS.  
MAXIMUM WEIGHT SHOULD NOT EXCEED 100KG.  
DO NOT USE WITHOUT ADULT SUPERVISION.  
ADULT ASSEMBLY REQUIRED.

## ESSENTIAL INFORMATION

- Recommended for children 3+ years
- Do not leave child unattended while in use
- Good safety practices should be followed at all times
- Read all instruction before using this product.



1-2 adults needed for assembly.









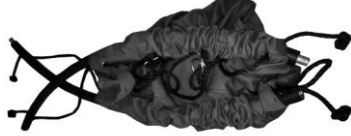

Hanging hardware not included. Ideally, the swing body should be hung over grass, sand, wood chips, or other soft surfaces. It should not be hung over concrete, asphalt, or other hard surfaces. Distance from ground should not exceed 40cm; there are two S-hooks attached to the ropes to allow for adjustment of the rope length.

Please be sure to examine the ropes regularly to check for wear. Rope will, in time, degrade. If the color of the rope has become pale, frays easily, or gives off a powdery material when rubbed between the fingers, we recommend you replace the rope.

Equipment should be hung in such a way that a distance of at least 2m is clear on either side. Can be hung on an A-frame or swing set or on a tree limb of a diameter of at least 25cm.

## Assembling your swing

		
<p>1. Canoe swing arrives in 4 pieces and 2 corner connectors</p>	<p>2. Before assembly, locate the six included screws and Allen wrench.</p>	<p>3. Lay the main body and 2 triangle connector in the right positions.</p>

 <p>4. Pass the metal tube into the fabric sleeves one by one.</p>	 <p>5. Connect the tube connections and repeat.</p>	 <p>6. Tighten it with a bolt and washer.</p>
 <p>7. Main frame assembly finished as above.</p>	 <p>8. Make the 2 fabric sleeves smooth and spread out after the metal tube assembly.</p>	 <p>9. Pull the hanging rope ends to the metal tube.</p>
 <p>10. After the rope end close to the metal tube, repeat this 4 times.</p>	 <p>11. After the 4 rope ends pulled, and make the swing body smooth for the triangle ends assembly.</p>	 <p>12. Put the 2 triangle ends as above.</p>
 <p>13. Lock and tighten the screws one by one, and then repeat it on the other triangle end.</p>	 <p>14. Tighten and lock the screws</p>	 <p>15. Put the 2 fabric covers over the triangle ends</p>

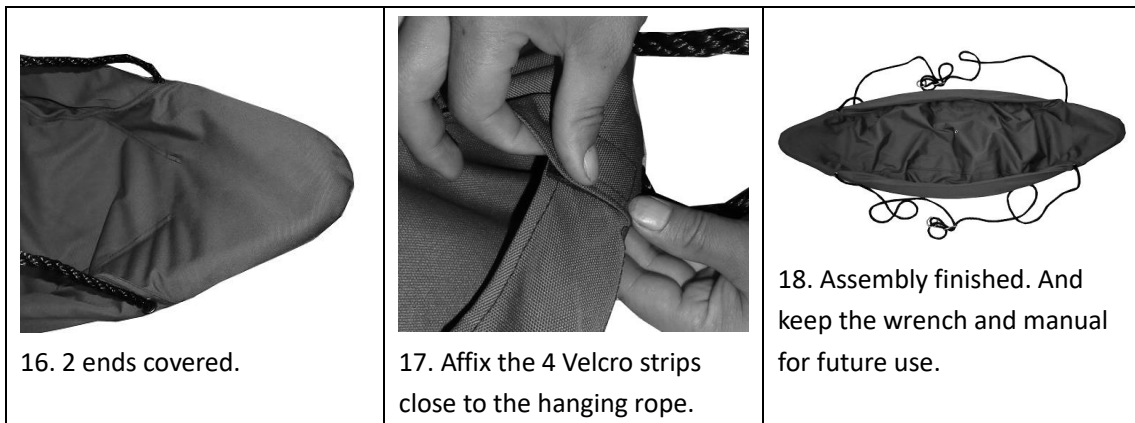

## Ensuring Safety of the Swing

Clearance distance should be 2m around the swing.

A fall onto a hard surface can result in serious injury to the equipment user.

Do not use the equipment until properly installed.

This swing is not to be used in any other manner other than its intended use.

Adult supervision is required.

Adults should verify that the hanging ropes are secured and cannot be looped back on the swing.

It is important for adults to instruct children to:

- Dress appropriately while using the swing (avoid ponchos, scarves, and other loose-fitting clothing that is potentially hazardous, or clothes with hard or sharp pieces that could damage the swing).
- Sit in the center of the swing with full weight on the seat if swinging alone
- Avoid swinging empty seats

It is important for adults to instruct children **NOT to**

- Walk close to, in front of, behind, or between moving items

- Twist ropes or loop them over the top support bar since such action may reduce the strength of the rope
- Get off the swing while it is in motion
- Climb on the swing when it is wet.
- Attach additional items to the swing.

## **Maintaining the Swing**

At the beginning of the each play season, adults should:

- Check and tighten hardware if necessary.
- Check all protective coverings on pipes, edges, and corners, Replace if they are loose, cracked, or missing.
- Check all moving parts including swing seat, ropes for wear, rust, or other deterioration, Replace as needed. The hardware used for this swing (binding post, screw, S hook, lock washer, flat washer, and metal ring) can be found at local hardware store.
- Check metal parts for rust, if found, and repaint using a non-lead-based paint meeting the EN71 requirements.
- If the swing is hung from swing set frame, then lubricate all metallic moving parts that are attached by a metal connection.
- If the swing is hung from a tree branch, then rake and check depth of loose-fill protective surfacing materials(such as mulch or sand) to prevent compaction and to maintain appropriate depth(Min amount is 25cm), replace as needed.